

BIM-BB+FF ▶ Roll/Fold to Batch/Fold

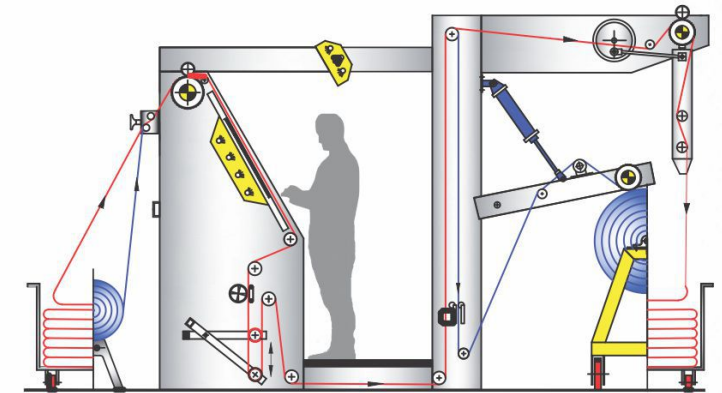

It's a Combi machine, where fabric can be feed in Roll or Fold form and it can deliver in Big-Batch form or Fold form. Due to its possibilities it saves lots of space and never stay idle. A mandatory machine for any inspection and make-up department.

This machine can work round the clock and increase the production, which makes it an essential weapon for any fabric manufacturer's armory.



Features:

-  Inspection
-  Platform
-  Delivery Big-Batcher
-  Delivery Plaiter
-  Accurate Edge Guider
-  Edge Guider
-  Mechanical Length Counter
-  Variable Speed
-  Dancing Compensator
-  Full Length Reversing
-  Italian Geared-Motor

Optional:

-  Feed Surface Big-Batcher
-  Feed Auto Stop
-  Electronic Counter
-  Anti-Slip Mechanism
-  Selvedge Shifting
-  S.S. Guide Rolls