

BIM-DRR+RR ▶ Roll to Roll

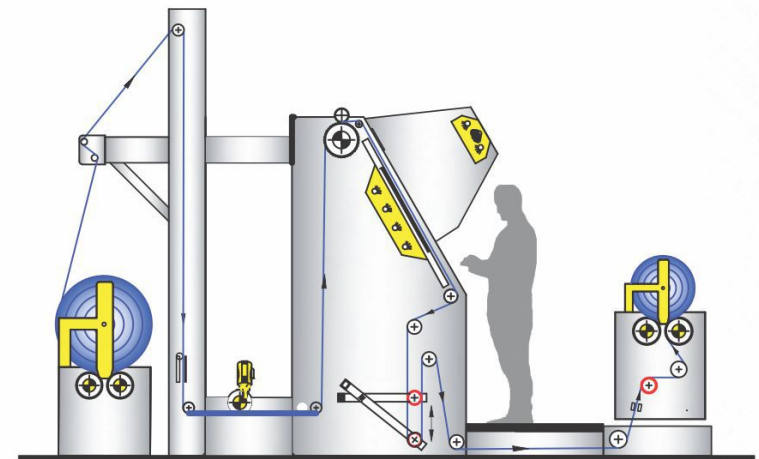

Jumbo Rolls can be easily Inspected and rolled as per desired length in this special designed machine. All the Drives are synchronised and ensures tensionless handling of fabric.

Due to heavy-duty driven un-winder it can handle bigger Roll diameter/weight. Edge trimmers can also be installed to produce straight and presentable fabric rolls.



Features:



Optional:

